



# ControlNet Daughtercard

## Catalog Numbers 1788-CNC and 1788-CNCR

This document describes how to install and configure the ControlNet 1788-CNC and -CNCR daughtercards. In this document, we use the term 'the card' to refer to both daughtercards collectively. When one card is different from the other, we refer to the daughtercard by name.

<b>For information about</b>	<b>See page</b>
Important User Information	2
European Hazardous Location Approval	4
North American Hazardous Location Approval	5
About the Daughtercards	6
Setting the Node Address	7
Installing the Card	8
Daughtercard Performance	8
Connecting the Card to the Network	8
Connect to the Network Using a Tap	10
Connect to the Network Using a 1786-CP Cable	12
Interpreting the Status Indicators	14
Specifications	17

If you are connecting the card directly to a ControlNet network, you should also refer to these publications:

- ControlNet Tap Installation Instructions, publication 1786-5.7
- ControlNet Coax Media Planning and Installation Guide, publication CNET-IN002

# Important User Information

## Important User Information

Solid state equipment has operational characteristics differing from those of electromechanical equipment. *Safety Guidelines for the Application, Installation and Maintenance of Solid State Controls* (Publication SGI-1.1 available from your local Rockwell Automation sales office or online at <http://www.ab.com/manuals/gi>) describes some important differences between solid state equipment and hard-wired electromechanical devices. Because of this difference, and also because of the wide variety of uses for solid state equipment, all persons responsible for applying this equipment must satisfy themselves that each intended application of this equipment is acceptable.





In no event will Rockwell Automation, Inc. be responsible or liable for indirect or consequential damages resulting from the use or application of this equipment.

The examples and diagrams in this manual are included solely for illustrative purposes. Because of the many variables and requirements associated with any particular installation, Rockwell Automation, Inc. cannot assume responsibility or liability for actual use based on the examples and diagrams.

No patent liability is assumed by Rockwell Automation, Inc. with respect to use of information, circuits, equipment, or software described in this manual.

Reproduction of the contents of this manual, in whole or in part, without written permission of Rockwell Automation, Inc. is prohibited.

Throughout this manual we use notes to make you aware of safety considerations.

<p><b>WARNING</b></p> 	<p>Identifies information about practices or circumstances that can cause an explosion in a hazardous environment, which may lead to personal injury or death, property damage, or economic loss.</p>
<p><b>IMPORTANT</b></p>	<p>Identifies information that is critical for successful application and understanding of the product.</p>
<p><b>ATTENTION</b></p> 	<p>Identifies information about practices or circumstances that can lead to personal injury or death, property damage, or economic loss. Attentions help you:</p> <ul style="list-style-type: none"> <li>• identify a hazard</li> <li>• avoid a hazard</li> <li>• recognize the consequence</li> </ul>
<p><b>SHOCK HAZARD</b></p> 	<p>Labels may be located on or inside the equipment to alert people that dangerous voltage may be present.</p>
<p><b>BURN HAZARD</b></p> 	<p>Labels may be located on or inside the equipment to alert people that surfaces may be dangerous temperatures.</p>

**ATTENTION****Environment and Enclosure**

This equipment is intended for use in a Pollution Degree 2 industrial environment, in overvoltage Category II applications (as defined in IEC publication 60664-1), at altitudes up to 2000 meters without derating.

This equipment is considered Group 1, Class A industrial equipment according to IEC/CISPR Publication 11. Without appropriate precautions, there may be potential difficulties ensuring electromagnetic compatibility in other environments due to conducted as well as radiated disturbance.

This equipment is supplied as “open type” equipment. It must be mounted within an enclosure that is suitably designed for those specific environmental conditions that will be present and appropriately designed to prevent personal injury resulting from accessibility to live parts. The interior of the enclosure must be accessible only by the use of a tool. Subsequent sections of this publication may contain additional information regarding specific enclosure type ratings that are required to comply with certain product safety certifications.

**NOTE:** See NEMA Standards publication 250 and IEC publication 60529, as applicable, for explanations of the degrees of protection provided by different types of enclosure. Also, see the appropriate sections in this publication, as well as the Allen-Bradley publication 1770-4.1 (“Industrial Automation Wiring and Grounding Guidelines”), for additional installation requirements pertaining to this equipment.

**ATTENTION****Preventing Electrostatic Discharge**

This equipment is sensitive to electrostatic discharge, which can cause internal damage and affect normal operation. Follow these guidelines when you handle this equipment:

- Touch a grounded object to discharge potential static.
- Wear an approved grounding wriststrap.
- Do not touch connectors or pins on component boards.
- Do not touch circuit components inside the equipment.
- If available, use a static-safe workstation.
- When not in use, store the equipment in appropriate static-safe packaging.

## European Hazardous Location Approval

### European Zone 2 Certification

**(The following applies when the product bears the EEx Marking.)**

This equipment is intended for use in potentially explosive atmospheres as defined by European Union Directive 94/9/EC.

The LCIE (Laboratoire Central des Industries Electriques) certifies that this equipment has been found to comply with the Essential Health and Safety Requirements relating to the design and construction of Category 3 equipment intended for use in potentially explosive atmospheres, given in Annex II to this Directive. The examination and test results are recorded in confidential report No. 28 682 010.

Compliance with the Essential Health and Safety Requirements has been assured by compliance with EN 50021.

---

#### **IMPORTANT**

- This equipment is not resistant to sunlight or other sources of UV radiation.
  - The secondary of a current transformer shall not be open-circuited when applied in Class I, Zone 2 environments.
  - Equipment of lesser Enclosure Type Rating must be installed in an enclosure providing at least IP54 protection when applied in Class I, Zone 2 environments.
  - This equipment shall be used within its specified ratings defined by Allen-Bradley.
  - Provision shall be made to prevent the rated voltage from being exceeded by transient disturbances of more than 40% when applied in Class I, Zone 2 environments.
-

## North American Hazardous Location Approval

<p>The following information applies when operating this equipment in hazardous locations:</p>	<p>Informations sur l'utilisation de cet équipement en environnements dangereux:</p>		
<p>Products marked "CL I, DIV 2, GP A, B, C, D" are suitable for use in Class I Division 2 Groups A, B, C, D, Hazardous Locations and nonhazardous locations only. Each product is supplied with markings on the rating nameplate indicating the hazardous location temperature code. When combining products within a system, the most adverse temperature code (lowest "T" number) may be used to help determine the overall temperature code of the system. Combinations of equipment in your system are subject to investigation by the local Authority Having Jurisdiction at the time of installation.</p>	<p>Les produits marqués "CL I, DIV 2, GP A, B, C, D" ne conviennent qu'à une utilisation en environnements de Classe I Division 2 Groupes A, B, C, D dangereux et non dangereux. Chaque produit est livré avec des marquages sur sa plaque d'identification qui indiquent le code de température pour les environnements dangereux. Lorsque plusieurs produits sont combinés dans un système, le code de température le plus défavorable (code de température le plus faible) peut être utilisé pour déterminer le code de température global du système. Les combinaisons d'équipements dans le système sont sujettes à inspection par les autorités locales qualifiées au moment de l'installation.</p>		
<p><b>WARNING</b></p>	<p><b>EXPLOSION HAZARD</b></p> <p>Do not disconnect equipment unless power has been removed or the area is known to be nonhazardous.</p> <p>Do not disconnect connections to this equipment unless power has been removed or the area is known to be nonhazardous. Secure any external connections that mate to this equipment by using screws, sliding latches, threaded connectors, or other means provided with this product.</p> <p>Substitution of components may impair suitability for Class I, Division 2.</p> <p>If this product contains batteries, they must only be changed in an area known to be nonhazardous.</p>	<p><b>AVERTISSEMENT</b></p>	<p><b>RISQUE D'EXPLOSION</b></p> <p>Couper le courant ou s'assurer que l'environnement est classé non dangereux avant de débrancher l'équipement.</p> <p>Couper le courant ou s'assurer que l'environnement est classé non dangereux avant de débrancher les connecteurs. Fixer tous les connecteurs externes reliés à cet équipement à l'aide de vis, loquets coulissants, connecteurs filetés ou autres moyens fournis avec ce produit.</p> <p>La substitution de composants peut rendre cet équipement inadapté à une utilisation en environnement de Classe I, Division 2.</p> <p>S'assurer que l'environnement est classé non dangereux avant de changer les piles.</p>

**WARNING**



- If you connect or disconnect the communications cable with power applied to this module or any device on the network, an electrical arc can occur. This could cause an explosion in hazardous location installations.
  - If you insert or remove the card while host power is on, an electrical arc can occur. This could cause an explosion in hazardous location installations.
  - Be sure that power is removed or the area is nonhazardous before proceeding.
- 

## About the Daughtercards

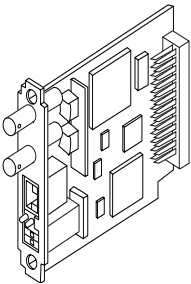

The network daughtercard architecture defines a common hardware and software interface that several different network interface cards will support. This allows products that have been designed to support the network daughtercard option to support several different Rockwell Automation networks.

## About the ControlNet Daughtercard

You can install the 1788-CNC or -CNCR ControlNet daughtercard in any host device that supports the ControlNet daughtercard.<sup>(1)</sup>

Every ControlNet network requires at least one module that is able to store parameters and configure the network with those parameters upon start-up. This module is called a ‘keeper’ since it keeps the network configuration.

Any 1788-CNC or -CNCR card can keep the network parameters at any legal node address (01 to 99). Multiple devices on any one network can act as the network keeper. Each device capable of being the network keeper acts to back up the current keeper. This backup function is automatic and requires no action on your part.

**IMPORTANT**

On the 1788-CNC or -CNCR card, the non-volatile keeper data is erased when a firmware update is performed.

---

<sup>(1)</sup> The host device must provide a suitable power source per the restrictions in the specifications table.

## Setting the Node Address

You must set two switch assemblies to configure the daughtercard with its unique network address. Figure 1 shows the location of the switches. These switches are read on powerup to establish the network address of the card.

Set the node address to a value between 01 and 99. For optimum throughput, assign addresses to your ControlNet nodes in a sequential order starting with 01.

Node address 00 is not a valid ControlNet address. You should only use node address 00 if the product that uses the ControlNet daughtercard has the ability to set the node address using the host device interface.

This feature is typically used on products that do not allow easy customer access to the node address switches. If you set the node address switch to 00, it allows the host in which the daughtercard resides to set the node address, rather than allowing the daughtercard to read the node address from the switch settings.

**Figure 1 Setting the Node Address**

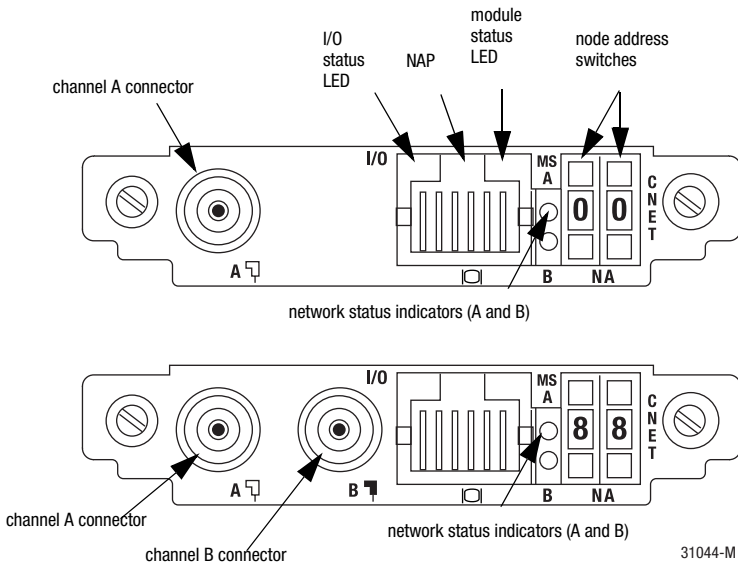

## Installing the Card

Due to wide variation in available host devices, we cannot provide specific installation instructions in this document. For instructions on how to install the daughtercard in a host device, refer to the user manual for the particular host device.

---

**IMPORTANT**

Do not install or remove the daughtercard while the host is under power.

---

## Daughtercard Performance

Due to wide variation in available host devices, we cannot provide specific performance capabilities in this document. For information concerning host/daughtercard performance characteristics, refer to the user manual for the particular host device.

## Connecting the Card to the Network

After you have installed the card, you can connect it to the network. You must connect the card to the network using an approved ControlNet tap:

- 1786-TPR (T-tap right angle)
- 1786-TPS (T-tap straight)
- 1786-TPYR (Y-tap right angle)
- 1786-TPYS (Y-tap straight)

We recommend the straight taps.

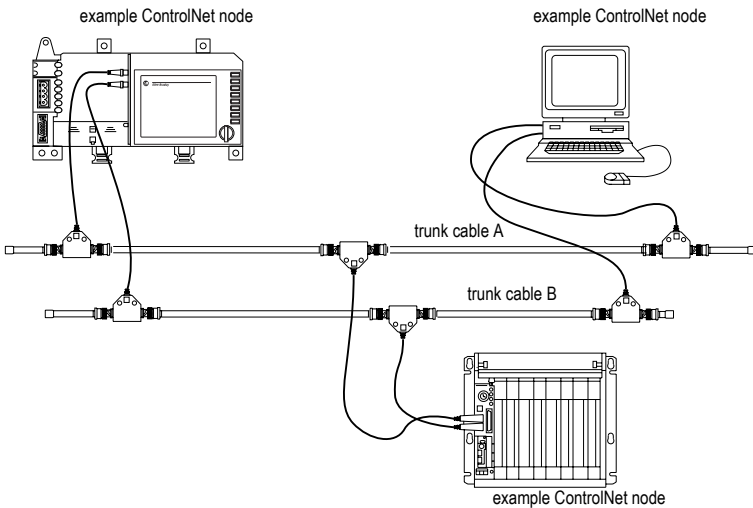

**Figure 2 1788-CNCR Daughtercard**

When you connect the daughtercard to a ControlNet network, you should also refer to this documentation:

- ControlNet Coax Tap Installation Instructions, publication 1786-5.7
- ControlNet Coax Media Planning and Installation Guide, publication CNET-IN002

See page 14 for information about status indicators.

**IMPORTANT**

If you use a non-redundant cable system, all ControlNet devices must be on the same channel, we recommend channel A.

## Connect to the Network Using a Tap

1. Remove and save the dust cap(s) from the ControlNet tap(s).

---

**ATTENTION**



Do not allow any metal portions of the tap to contact any conductive material. If you disconnect the tap from the module, place the dust cap back on the straight or right angle connector to prevent the connector from accidentally contacting a metallic grounded surface.

---

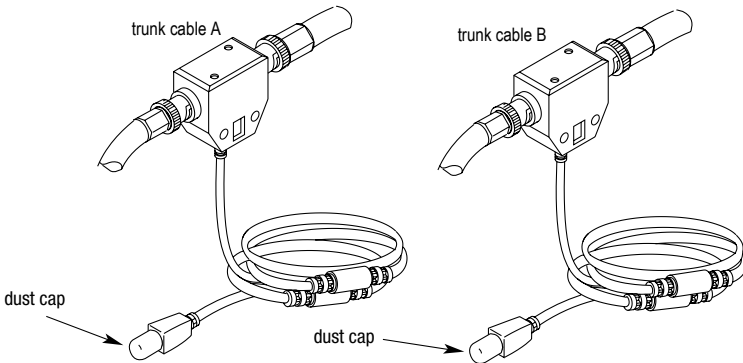

1788-CNC use trunk cable A.  
1788-CNCR use trunk cable A and B.

20955-M

2. Connect the tap's straight or right-angle connector to the module's BNC connector.

If your network supports	Connect the tap's straight or right-angle connector
non-redundant media (1788-CNC or -CNCR)	to the <b>channel A</b> connector on the module <b>(channel B on the 1788-CNCR is not used.)</b> <sup>1</sup>
redundant media (1788-CNCR)	from <b>trunk-cable A</b> to <b>channel A</b> on the 1788-CNCR and from <b>trunk-cable B</b> to <b>channel B</b> on the 1788-CNCR.

1. Rockwell Automation recommends using channel A for non-redundant media.

## IMPORTANT

To prevent inadvertent reversal of the tap connections (resulting in incorrect status displays and troubleshooting), check the tap drop cable for a label indicating the attached cable before you make your connection.

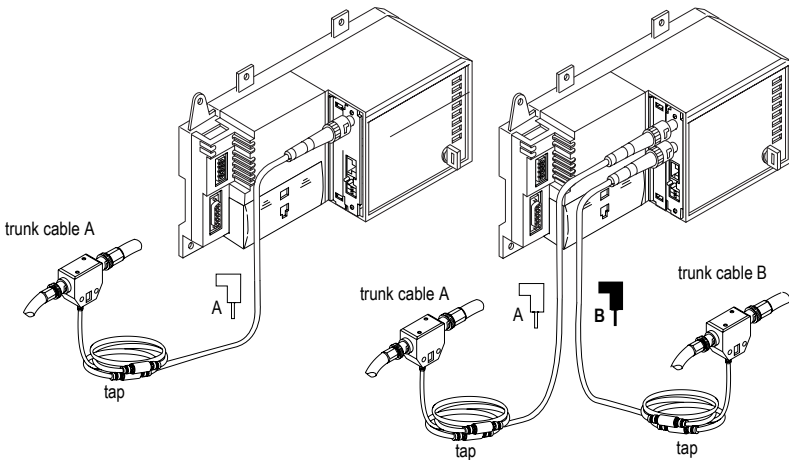

## Connect to the Network Using a 1786-CP Cable

Follow this illustration to connect a programming terminal to the network using a 1786-CP cable.

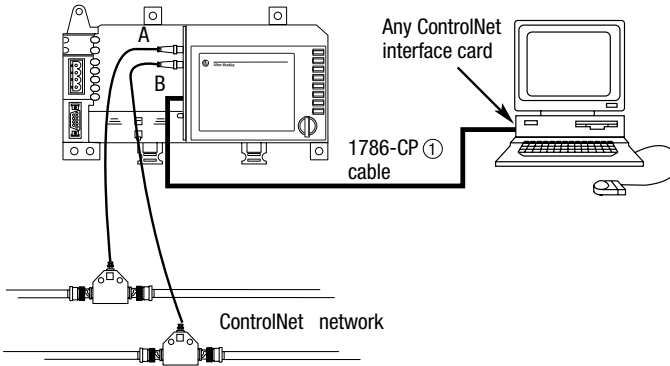

- ① The 1786-CP cable can be plugged into any ControlNet product's NAP to provide programming capability on the ControlNet network. A programming terminal connected through this cable is counted as a node and must have a unique address.

31074-M

### ATTENTION



Use the 1786-CP cable when you connect a programming terminal to the network through the network access port (NAP); using another cable could result in possible network failures or product damage.

The NAP port is for temporary local programming purposes only and not intended for permanent connection.

This table shows the wiring for the 1786-CP connector cable.

<b>Connector 1</b>		
Wire Number	Signal Mnemonic	Signal Name
1	ISO-GND	Isolated Ground
2	N.C.	No Connection
3	PTTX-H	Transmit Data High
4	PTTX-L	Transmit Data Low
5	PTRX-L	Receive Data Low
6	PTRX-H	Receive Data High
7	N.C.	No Connection
8	ISO-GND	Isolated Ground

<b>Connector 2</b>		
Wire Number	Signal Mnemonic	Signal Name
1	ISO-GND	Isolated Ground
2	N.C.	No Connection
3	PTRX-H	Receive Data High
4	PTRX-L	Receive Data Low
5	PTTX-L	Transmit Data Low
6	PTTX-H	Transmit Data High
7	N.C.	No Connection
8	ISO-GND	Isolated Ground

## Interpreting the Status Indicators

Status indicators provide information about the card and the network when you are connected via the BNC connectors. Tables 1 and 2 on the following pages outline the possible states, explain what each state means to you, and indicate what action you should take, if any, to correct that state.

Definition of terms:

- **steady** - indicator is on continuously in the defined state.
- **alternating** - the two indicators alternate between the two defined states at the same time (applies to both indicators when *viewed together*); the two indicators are always in opposite states, out of phase.
- **flashing** - the indicator alternates between the two defined states (applies to each indicator *viewed independent* of the other); if both indicators are flashing, they flash together, in phase.

---

### IMPORTANT

Keep in mind that the Module Status indicator reflects the module state, e.g., self-test, firmware update, normal operation but no connection established, etc. The network status LEDs, A and B, reflect network status. Remember that the host is able to engage in local messaging with the card although it is detached from the network. Therefore, the Module Status LED is flashing green if the host has successfully started the card. Note, however, that until the host removes reset, all LEDs on the daughtercard will remain off.

When you view the indicators, always view the Module Status indicator first to determine the state of the daughtercard. This information may help you to interpret the network status indicators. As a general practice, view all three status indicators (Module Status, I/O Status, and Network Status) together to gain a full understanding of the daughtercard's status.

---

**Table 1 Interpreting Module and I/O Status**

Indicator	Color	Probable Cause(s)	Recommended Action
Module Status (MS)	Off	<ul style="list-style-type: none"> <li>No power</li> <li>Host is faulted</li> <li>Host is holding daughtercard in reset</li> </ul>	<ul style="list-style-type: none"> <li>Check the power supply.</li> <li>Ensure that the daughtercard is firmly seated in the slot.</li> <li>Cycle power. If the indicator remains off, replace the daughtercard or the host.</li> </ul>
	Steady Red	Major fault	There is a hardware fault with the module. Cycle power. If the problem persists, replace the daughtercard.
	Flashing Red	<ul style="list-style-type: none"> <li>Minor fault</li> <li>Firmware update in progress</li> <li>Node address switch change</li> <li>Invalid module firmware</li> <li>Duplicate node address</li> </ul>	<ul style="list-style-type: none"> <li>No action required (firmware update in progress.)</li> <li>The daughtercard's node address switches may have been changed since power-up. Change the node address switches back to the original setting. The module will continue to operate properly.</li> <li>Update module firmware with ControlFlash Update utility.</li> <li>The daughtercard's node address duplicates that of another device. Remove power, change the node address to a unique setting, then apply power.</li> </ul>
	Flashing Green	No connections established	No action required.
	Steady Green	Connections established	No action required.
	Flashing Red/Green	Self-test	The module is performing self-diagnostics. Wait briefly to see if problem corrects itself. If problem persists, check the host. If the daughtercard cannot communicate with the host, it may remain in self-test mode.
I/O Status (I/O)	Always Off		This LED is on during the LED portion of the self-tests.

**Table 2 Interpreting Network Status**

<b>Indicator</b>	<b>Color</b>	<b>Probable Cause</b>	<b>Recommended Action</b>
A or B (when viewed independently)	Off	Channel disabled	Program network for redundant media, if required.
	Steady Green	Normal operation	No action required.
	Flashing Green/Off	Temporary network errors	None, unit will self-correct
		Node is not configured to go on line	Make sure the configuration keeper node is present and working.
	Flashing Red/Off	Media fault	<ul style="list-style-type: none"> <li>• Check media for broken cables, loose connectors, missing terminators, etc.</li> <li>• If condition persists, refer to ControlNet Coax Media Planning and Installation Manual, publication CNET-IN002.</li> </ul>
		No other nodes present on network	Add other nodes to the network.
Flashing Red/Green	Incorrect network configuration	Cycle power or reset unit. If fault persists, contact your Rockwell Automation representative or distributor.	
<b>Indicator</b>	<b>Color</b>	<b>Probable Cause</b>	<b>Recommended Action</b>
A and B (when viewed together)	Off	See the MS indicator for additional information.	No action required or apply power.
	Steady Red	Faulted unit	Cycle power or reset unit. If fault persists, contact your Rockwell Automation representative or distributor.
	Alternating Red/Green	Self-test	No action required.
	Alternating Red/Off	Incorrect node configuration	Check network address and other ControlNet configuration parameters.



## Specifications

Characteristic	Value
Operational Temperature	IEC 60068-2-1 (Test Ad, Operating Cold), IEC 60068-2-2 (Test Bd, Operating Dry Heat), IEC 60068-2-14 (Test Nb, Operating Thermal Shock): 0 to 60°C (32 to 140°F) It is acceptable for the ambient slot temperature immediately surrounding this product to reach 85°C (185°F) maximum
Storage Temperature	IEC 60068-2-1 (Test Ab, Un-packaged Non-operating Cold), IEC 60068-2-2 (Test Bb, Un-packaged Non-operating Dry Heat), IEC 60068-2-14 (Test Na, Un-packaged Non-operating Thermal Shock): -40 to 85°C (-40 to 185°F)
Relative Humidity	IEC 60068-2-30 (Test Db, Un-packaged Non-operating Damp Heat): 5 to 95% non-condensing
Vibration	IEC 60068-2-6 (Test Fc, Operating): 5g @ 10-500Hz
Operating Shock	IEC 60068-2-27 (Test Ea, Unpackaged Shock): 30g
Non-Operating Shock	IEC 60068-2-27 (Test Ea, Unpackaged Shock): 50g
Emissions	CISPR 11: Group 1, Class A
ESD Immunity	IEC 61000-4-2: 6kV contact discharges 8kV air discharges
Radiated RF Immunity	IEC 61000-4-3: 10V/m with 1kHz sine-wave 80%AM from 30MHz to 1000MHz 10V/m with 200Hz 50% Pulse 100%AM at 900Mhz
EFT/B Immunity	IEC 61000-4-4: ±4kV at 2.5kHz on communications ports
Surge Transient Immunity	IEC 61000-4-5: ±2kV line-earth(CM) on shielded ports
Conducted RF Immunity	IEC 61000-4-6: 10Vrms with 1kHz sine-wave 80%AM from 150kHz to 80MHz
Enclosure Type Rating	None (open-style)
Power Requirements <sup>(1)</sup> 1788-CNC 1788-CNCR	5V dc @ 450 mA (maximum) 5V dc @ 475 mA (maximum)
Power Consumption 1788-CNC 1788-CNCR	2.25 watts 2.375 watts
Power Dissipation 1788-CNC 1788-CNCR	2.25 watts or 7.68 BTU/hour 2.375 watts or 8.1 BTU/hour
Wiring Category <sup>(2)</sup>	2 - on communications ports

Weight 1788-CNC, 1788-CNCR	0.1 Kg (0.2 lb)
Agency Certification (when product is marked)	<p><b>c-UR-us:</b> UL Recognized Component Industrial Control Equipment, certified for US and Canada</p> <p><b>c-UR-us:</b> UL Recognized Component Industrial Control Equipment for Class I, Division 2, Group A,B,C,D Hazardous Locations, certified for US and Canada</p> <p><b>CSA:</b> CSA Certified Process Control Equipment</p> <p><b>CSA:</b> CSA Certified Process Control Equipment for Class I, Division 2, Group A,B,C,D Hazardous Locations</p> <p><b>CE</b><sup>(3)</sup>: European Union 89/336/EEC EMC Directive, compliant with:  EN 50082-2; Industrial Immunity  EN 61326; Meas./Control/Lab., Industrial Requirements  EN 61000-6-2; Industrial Immunity  EN 61000-6-4; Industrial Emissions</p> <p><b>C-Tick</b><sup>(3)</sup>: Australian Radiocommunications Act, compliant with:  AS/NZS CISPR 11; Industrial Emissions</p> <p><b>Ex</b><sup>(3)</sup>: European Union 94/9/EC ATEX Directive, compliant with:  EN 50021; Potentially Explosive Atmospheres, Protection "n" (Zone 2)</p> <p><b>CI:</b> ControlNet International conformance tested to ControlNet specifications</p>

- (1) To comply with UL and CSA restrictions, this equipment must be powered from a source compliant with the following: Class 2 or Limited Voltage/Current, as defined in UL 508 Seventeenth Edition Section 32; and Separated Extra-Low-Voltage (SELV), as defined in CSA C22.2 No 1010, Annex H.
- (2) Use this Conductor Category information for planning conductor routing. Refer to Publication 1770-4.1, "Industrial Automation Wiring and Grounding Guidelines".
- (3) See the Product Certification link at [www.ab.com](http://www.ab.com) for Declarations of Conformity, Certificates, and other certification details.

**Notes:**

# Rockwell Automation Support

Rockwell Automation provides technical information on the web to assist you in using our products. At <http://support.rockwellautomation.com>, you can find technical manuals, a knowledge base of FAQs, technical and application notes, sample code and links to software service packs, and a MySupport feature that you can customize to make the best use of these tools.

For an additional level of technical phone support for installation, configuration and troubleshooting, we offer TechConnect Support programs. For more information, contact your local distributor or Rockwell Automation representative, or visit <http://support.rockwellautomation.com>.

## Installation Assistance

If you experience a problem with a hardware module within the first 24 hours of installation, please review the information that's contained in this manual. You can also contact a special Customer Support number for initial help in getting your module up and running:

United States	1.440.646.3223 Monday – Friday, 8am – 5pm EST
Outside United States	Please contact your local Rockwell Automation representative for any technical support issues.

## New Product Satisfaction Return

Rockwell tests all of our products to ensure that they are fully operational when shipped from the manufacturing facility. However, if your product is not functioning and needs to be returned:

United States	Contact your distributor. You must provide a Customer Support case number (see phone number above to obtain one) to your distributor in order to complete the return process.
Outside United States	Please contact your local Rockwell Automation representative for return procedure.

[www.rockwellautomation.com](http://www.rockwellautomation.com)

### Power, Control and Information Solutions Headquarters

Americas: Rockwell Automation, 1201 South Second Street, Milwaukee, WI 53204-2496 USA, Tel: (1) 414.382.2000, Fax: (1) 414.382.4444

Europe/Middle East/Africa: Rockwell Automation, Vorstlaan/Boulevard du Souverain 36, 1170 Brussels, Belgium, Tel: (32) 2 663 0600, Fax: (32) 2 663 0640

Asia Pacific: Rockwell Automation, Level 14, Core F, Cyberport 3, 100 Cyberport Road, Hong Kong, Tel: (852) 2887 4788, Fax: (852) 2508 1846

Publication 1788-IN002C-EN-P - April 2004

PN 957867-24

Supersedes Publication 1788-IN002B-EN-P - August 2000

Copyright © 2004 Rockwell Automation, Inc. All rights reserved. Printed in the U.S.A.